

RT SERIES

PNEUMATIC RACK & PINION ACTUATOR

INCOAIR™



RT SERIES

PNEUMATIC RACK & PINION ACTUATOR

DESIGN AND INNOVATION



The RT Series pneumatic actuators are available in:

- Optional reverse rotation from counter clockwise to clockwise.
- Sixteen different sizes covering a wide application range.
- Spring return and double acting versions.
- Torque up to 13,000 Nm.
- Low and high temperature conditions.
- Large selection of ISO flange mounting and drive shaft connections for direct valve automation.

Options available on request:

- 120°, 135°, 180° rotation both in double acting and spring return.
- 180° spring return Fail-End and Fail-Mid.
- 3 Position actuators, 90° and 180° rotation, both double acting and spring return versions.
- Fast or slow valve actuation.
- Hydraulic damper actuators.
- 100% travel stop adjustment.



TECHNICAL FEATURES

1. ANODIZED ALUMINUM ALLOY BODY

- Extruded aluminum body with anodized treatment for internal and external protection.
- Internal cylinder surface is honed for a higher life cycle and lower frictions.
- Additional external protective coatings available for harsh environmental working conditions.



2. PISTON DESIGN

- Dual rack and pinion design:
 - Compact Construction
 - Symmetric Mounting Position
 - High Life Cycle
 - Fast Operation
- Simple on site reverse piston position.
- Anodized pistons for better corrosion and wear resistance.



3. ADJUSTABLE TRAVEL STOPS

- Two independent travel stops allows +/- 5 degrees adjustment in the open or closed position.



4. FASTNERS

- Stainless Steel for corrosion resistance.

5. BLOWOUT PROOF DRIVE SHAFT

- Alloy steel drive shaft with pinion guided bearing for improved safety and high life cycle.
- Stainless steel or other alloys available (option).



RT SERIES

PNEUMATIC RACK & PINION ACTUATOR

TECHNICAL FEATURES

6. COMPACT DESIGN

- Allows easy conversion from double acting to spring return.

7. BEARINGS AND GUIDES

- Replaceable bearings and guides.
- Provide low friction and reliable performance.
- No metal to metal contact.

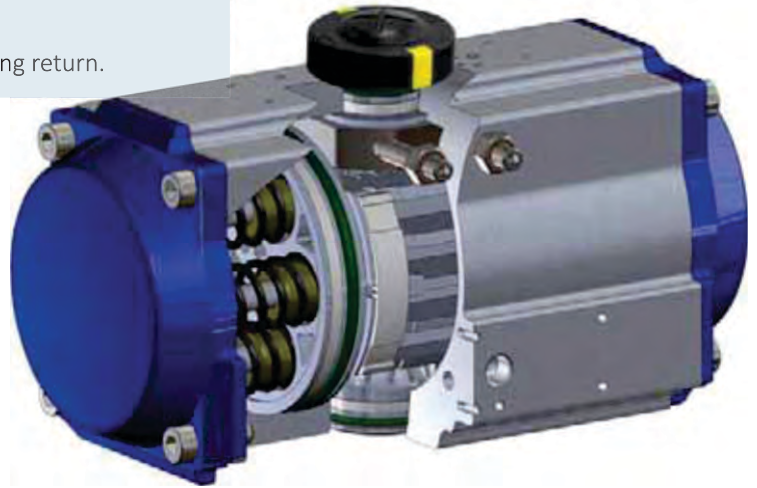

8. SPRING CARTRIDGE

- Coated springs for corrosion resistance.
- Easy to disassemble without any danger.

9. FULL COMPLIANCE

- Interface drilling of the process valve in accordance with ISO 5211 standard.
- Air connections in accordance with NAMUR VDI/VDE 3845 drilling.



OPERATING PRINCIPLES

DOUBLE ACTING



Standard Rotation

A ↑ ↓ B

Air to Port A forces the pistons outward, causing the pinion to turn counterclockwise while the air is being exhausted from Port B.



A ↓ ↑ B

Air to Port B forces the pistons inward, causing the pinion to turn clockwise while the air is being exhausted from Port A.



Reverse Rotation

A ↑ ↓ B

Air to Port A forces the pistons outward, causing the pinion to turn clockwise while the air is being exhausted from Port B.



A ↓ ↑ B

Air to Port B forces the pistons inward, causing the pinion to turn counterclockwise while the air is being exhausted from Port A.

SPRING RETURN



Standard Rotation
FAIL CLOSED

A ↑ ↓ B

Air to port A forces the pistons outward, causing the springs to compress. The pinion turns counterclockwise while air is being exhausted from port B.



A ↓ ↑ B

Loss of air pressure on port A, the springs force the pistons inward. The pinion turns clockwise while air is being exhausted from port A.



Reverse Rotation
FAIL OPEN

A ↑ ↓ B

Air to port A forces the pistons outward, causing the springs to compress. The pinion turns clockwise while air is being exhausted from port B.



A ↓ ↑ B

Loss of air pressure on port A, the springs force the pistons inward. The pinion turns clockwise while air is being exhausted from port A.



RT SERIES

PNEUMATIC RACK & PINION ACTUATOR

OPERATING CONDITIONS

Spring Configuration



Operating Conditions

1. Operating media

- Filtered air with or without lubrication. Lubrication should be continued once applied.
- Maximum particle size, 50 microns.

2. Supply pressure

- Maximum 8 Bar (120 PSI) air pressure.
- Minimum 2.5 Bar (35 PSI) air pressure.

3. Lubrication

- Factory lubricated for maximum life cycle under normal operating conditions.

4. Temperature Range

- Standard Range :-20 °C to 80°C (-4 °F to 176 °F).
- Low Temperature (optional) :-40°C to 80°C (-40°F to 176°F).
- High Temperature (optional) :-15°C to 150°C (5 °F to 302 °F).
- Extreme Low Temperature (optional) :-55°C to 80°C (-67 °F to 176 °F).

5. Installation

- Actuator suitable both for indoor and outdoor installation.

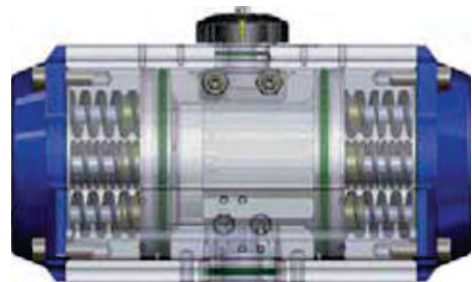

DIMENSIONS

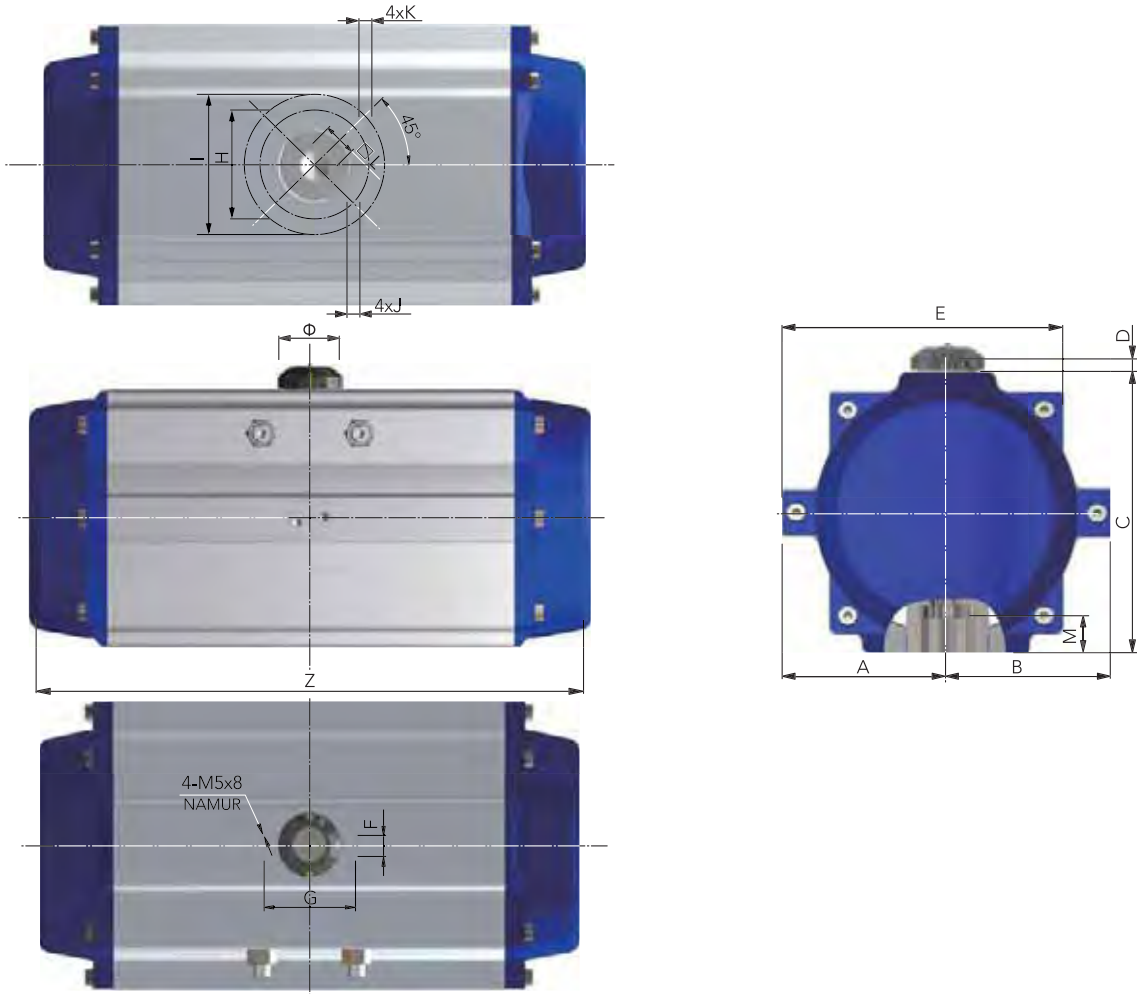

Unit: mm

Model	A	B	C	D	E	F	G	H	I	J	K	L	M	Z	Φ	Air Connection
RT020DA	30	42	72	92	65	30	80	Φ36	Φ50	4-M5x8	4-M6x10	11	14	150	Φ40	NAMUR G1/4"
RT035DA	35	48	88	108	72	30	80	Φ50	Φ70	4-M6x10	4-M8x13	14	18	170	Φ40	NAMUR G1/4"
RT050DA	43	55	100	120	80	30	80	Φ50	Φ70	4-M6x10	4-M8x13	14	18	185	Φ40	NAMUR G1/4"
RT075DA	48	58	110	130	90	30	80	Φ50	Φ70	4-M6x10	4-M8x13	17	21	205	Φ40	NAMUR G1/4"
RT110DA	50	60	120	140	98	30	80	Φ50	Φ70	4-M6x10	4-M8x13	17	21	265	Φ40	NAMUR G1/4"
RT160DA	58	65	135	155	110	30	80	Φ70	Φ102	4-M8x13	4-M10x16	22	26	270	Φ40	NAMUR G1/4"
RT255DA	68	75	155	175	125	30	80	Φ70	Φ102	4-M8x13	4-M10x16	22	26	300	Φ60	NAMUR G1/4"
RT435DA	75	78	175	195	140	30	80	Φ102	Φ125	4-M10x16	4-M12x20	27	31	395	Φ60	NAMUR G1/4"
RT665DA	88	88	198	218	160	30	80	Φ102	Φ125	4-M10x16	4-M12x20	27	31	460	Φ60	NAMUR G1/4"
RT1000DA	105	105	230	260	190	30	130	/	Φ140	/	4-M16x25	36	40	525	Φ90	NAMUR G1/4"
RT1200DA	115	115	255	285	210	30	130	/	Φ140	/	4-M16x25	36	40	535	Φ90	NAMUR G1/4"
RT1800DA	130	130	290	320	245	30	130	/	Φ165	/	4-M20x25	46	50	600	Φ90	NAMUR G1/4"
RT2700DA	145	147	330	360	275	30	130	/	Φ165	/	4-M20x25	46	50	720	Φ90	NAMUR G1/2"
RT3800DA	205	205	350	380	290	30	130	/	Φ165	/	4-M20x25	46	60	760	Φ90	NAMUR G1/2"
RT5700DA	230	230	410	440	335	30	130	Φ165	Φ254	4-M20x25	8-M16x25	46	60	890	Φ90	NAMUR G1/2"
RT8000DA	260	260	485	515	360	30	130	Φ165	Φ254	4-M20x25	8-M16x25	55	60	930	Φ90	NAMUR G1/2"



RT SERIES

PNEUMATIC RACK & PINION ACTUATOR

PARTS AND MATERIALS

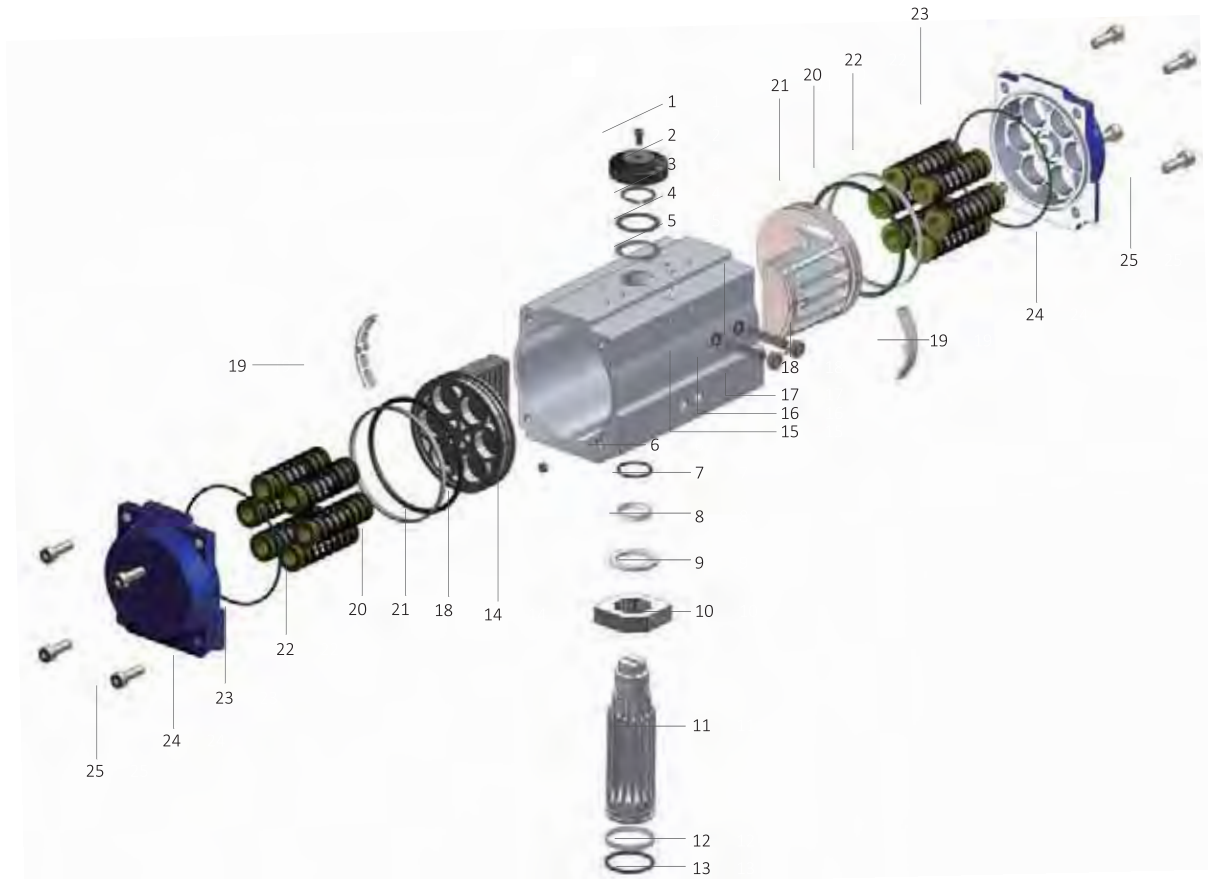

NO.	DESCRIPTION	QTY.	STANDARD MATERIAL	PROTECTION	OPTIONAL MATERIAL
1	Indicator Screw	1	Stainless Steel		
2	Indicator	1	Plastic		
3	Spring Clip	1	Stainless Steel		
4	Thrust Washer	1	Stainless Steel		
5	Outside Washer	1	Engineered Plastic		PTFE
6	Body	1	Extruded Alluminum Alloy	Anodized	Other on request
7	O-ring (pinion top)	1	NBR		Viton/Silicone
8	Bearing (pinion top)	1	Engineered Plastic		PTFE
9	Inside Washer	1	Engineered Plastic		PTFE
10	Cam	1	Steel Alloy		
11	Pinion	1	Steel Alloy	Nickel Plated	Stainless Steel
12	O-ring (pinion bottom)	1	NBR		Viton / Silicone
13	Bearing (pinion bottom)	1	Engineered Plastic		PTFE
14	Plug	2	NBR		Viton / Silicone
15	O-ring (adjustment screw)	2	NBR		Viton / Silicone
16	Adjustment Screw	2	Stainless Steel		
17	Nut (adjustment screw)	2	Stainless Steel		
18	Piston	2	Cast Alluminum Alloy	Anodized/Zinc Galvanized	Stainless Steel
19	Guide (piston)	2	Engineered Plastic		PTFE
20	Bearing (piston)	2	Engineered Plastic		PTFE
21	O-ring (piston)	2	NBR		Viton / Silicone
22	Spring	0~12	Steel Spring	Dip Coating	
23	O-ring (end cap)	2	NBR		Viton / Silicone
24	End Cap	2	Cast Alluminum	Polyester Powder Coated	Other on request
25	Cap Screw	8	Stainless Steel		

RT SERIES

PNEUMATIC RACK & PINION ACTUATOR

TORQUE OUTPUT (Nm)

SPRING RETURN

Torque: Nm

Air pressure		Output Torque: Air to Spring																				Spring Output			
		2 BAR		2.5 BAR		3 BAR		4 BAR		4.5 BAR		5 BAR		5.5 BAR		6 BAR		7 BAR		8 BAR		90°	0°		
Model	Spring Qty.	0° Start	90° End	0° Start	90° End	0° Start	90° End	0° Start	90° End	0° Start	90° End	0° Start	90° End	0° Start	90° End	0° Start	90° End	0° Start	90° End	0° Start	90° End	Start	End		
RT665DA	5	120	48	187	115	254	182																208	140	
	6			158	71	225	138	358	271														250	168	
	7					195	94	329	228	409	308	462	361										292	196	
	8							299	184	380	264	433	317	500	384								333	223	
	9							270	140	350	220	404	273	470	340	537	407						375	251	
	10							241	96	321	176	374	230	441	296	508	363	641	497				417	279	
	11											345	186	412	253	478	319	612	453	746	587		458	307	
	12													382	209	449	276	583	409	716	543		500	335	
	RT1000DA	5	220	105	328	213	436	321																309	200
		6			286	148	393	255	609	471														371	240
		7					351	190	567	406	696	535	782	621										433	280
		8							525	341	654	470	740	556	848	664								495	320
9								482	275	612	405	698	491	805	598	913	706						557	360	
10								440	210	570	340	656	426	763	533	871	641	1086	856				619	400	
11												614	361	721	468	829	576	1044	791	1260	1007		681	440	
12														679	403	787	511	1002	726	1218	942		742	480	
RT1200DA		5	223	108	355	239	486	371																398	288
		6			294	155	425	287	689	550														477	346
		7					365	203	628	466	786	624	891	729										557	403
		8							567	383	725	541	830	646	962	777								636	461
	9							507	299	665	457	770	562	901	694	1033	825						716	518	
	10							446	215	604	373	709	478	841	610	972	741	1235	1005				795	576	
	11											648	395	780	526	912	658	1175	921	1438	1184		875	634	
	12													719	442	851	574	1114	837	1377	1100		954	691	
	RT1800DA	5	341	190	534	383	728	577																554	410
		6			448	267	641	460	1028	847														665	492
		7					555	343	942	730	1174	962	1328	1117									776	575	
		8							855	613	1087	845	1242	1000	1435	1193								886	657
9								769	497	1001	729	1155	883	1349	1077	1542	1270						997	739	
10								682	380	914	612	1069	767	1262	960	1456	1153	1842	1540				1108	821	
11												983	650	1176	843	1369	1037	1756	1423	2142	1810		1219	903	
12														1089	727	1283	920	1669	1306	2056	1693		1330	985	
RT2700DA		5	585	347	879	640	1173	934																786	559
		6			761	475	1055	768	1642	1356														943	671
		7					937	603	1524	1190	1876	1542	2111	1777										1101	783
		8							1406	1024	1759	1377	1994	1612	2287	1905								1258	895
	9							1289	859	1641	1211	1876	1446	2169	1740	2463	2033						1415	1007	
	10							1171	693	1523	1046	1758	1281	2052	1574	2345	1868	2932	2455				1572	1119	
	11											1640	1115	1934	1409	2227	1702	2814	2289	3402	2877		1730	1231	
	12													1816	1243	2110	1537	2697	2124	3284	2711		1887	1343	
	RT3800DA	5	696	339	1077	720	1459	1102																1128	789
		6			911	483	1293	865	2056	1628														1353	946
		7					1127	627	1890	1390	2348	1848	2653	2153									1579	1104	
		8							1724	1153	2182	1611	2487	1916	2868	2297								1804	1262
9								1558	915	2016	1373	2321	1678	2702	2060	3084	2441						2030	1419	
10								1392	678	1850	1136	2155	1441	2536	1822	2918	2204	3681	2967				2255	1577	
11												1989	1203	2370	1585	2752	1967	3515	2730	4278	3493		2481	1735	
12														2204	1348	2586	1729	3349	2492	4112	3255		2707	1893	
RT5700DA		5	981	393	1553	964	2124	1536																1797	1238
		6			1292	586	1863	1157	3005	2300														2156	1486
		7					1602	779	2745	1921	3430	2607	3887	3064										2516	1734
		8							2484	1543	3169	2229	3626	2686	4198	3257								2875	1981
	9							2223	1165	2909	1850	3366	2307	3937	2878	4508	3450						3235	2229	
	10							1963	787	2648	1472	3105	1929	3676	2500	4247	3071	5390	4214				3594	2477	
	11											2844	1551	3416	2122	3987	2693	5129	3835	6272	4978		3953	2724	
	12													3155	1744	3726	2315	4868	3457	6011	4600		4313	2972	
	RT8000DA	5	1798	970	2611	1783																		2172	1385
		6	1506	512	2320	1326	3134	2140	4762	3768														2606	1662
		7			2028	869	2842	1683	4470	3311	5447	4287												3040	1939
		8					2551	1226	4178	2854	5155	3830												3475	2216
9								3887	2396	4863	3373	5514	4024										3909	2493	
10								3595	1939	4572	2916	5223	3567	6037	4381								4343	2770	
11										4280	2459	4931	3110	5745	3924	6559	4737						4778	3047	
12										3989	2001	4640	2652	5454	3466	6267	4280	7895	5908	9523	7536		5212	3324	
13														4348	2195	5162	3009	5976	3823	7604	5451	9231	7079	5646	3601
14														4056	1738	4870	2552	5684	3366	7312	4994	8940	6621	6081	3878
15														4579	2095	5393	2909	7020	4536	8648	6164		6515	4155	
16																		5101	2451	6729	4079	8357	5707	6949	4432

TORQUE OUTPUT

DOUBLE ACTING

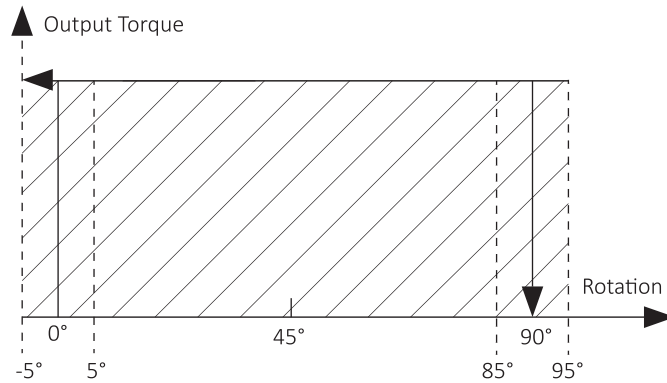

Torque: Nm

Model	Air supply pressure (Bar)									
	2	2.5	3	4	4.5	5	5.5	6	7	8
RT020DA	8.1	10.1	12.1	16.1	18.6	20.2	22.2	24.2	28.2	32.3
RT035DA	14.2	17.8	21.3	28.4	32.7	35.5	39.1	42.6	49.7	56.8
RT050DA	20.1	25.2	30.2	40.3	46.3	50.3	55.4	60.4	70.5	80.5
RT075DA	30.8	38.5	46.2	61.6	70.9	77.1	84.8	92.5	107.9	123.3
RT110DA	45.4	56.8	68.2	90.9	104.5	113.6	125.0	136.3	159.1	181.8
RT160DA	65.8	82.2	98.7	131.6	151.3	164.4	180.9	197.3	230.2	263.1
RT255DA	102.5	128.2	153.8	205.1	235.8	256.4	282.0	307.6	358.9	410.2
RT435DA	175	219	263	351	403	439	482	526	614	702
RT665DA	267	334	401	535	615	668	735	802	935	1069
RT1000DA	431	538	646	861	991	1077	1185	1292	1508	1723
RT1200DA	526	658	789	1052	1210	1316	1447	1579	1842	2105
RT1800DA	773	966	1160	1546	1778	1933	2126	2320	2706	3093
RT2700DA	1174	1468	1761	2349	2701	2936	3229	3523	4110	4697
RT3800DA	1526	1908	2289	3052	3510	3815	4197	4578	5341	6104
RT5700DA	2285	2856	3427	4570	5255	5712	6283	6854	7997	9139
RT8000DA	3256	4069	4883	6511	7488	8139	8953	9767	11394	13022



RT SERIES

PNEUMATIC RACK & PINION ACTUATOR

SIZING INFORMATION

Example for sizing a double-acting pneumatic actuator

Breakaway torque on control valve:

- Torque required to open the valve under a specific operating condition (fluid, temperature, operating pressure, etc.).

Air supply

- Minimum air supply pressure available.

Valve type

- Ball Valve, Butterfly Valve, etc.

Operating conditions

- Temperature, concentration, viscosity of the fluid.
- Gas or liquid, lubricating or non-lubricating.
- Presence of solids that form deposits.
- Differential pressure across the valve.

If no safety factor is specified, a minimum factor of 1.3 (30% safety) should be considered when sizing the BR Series pneumatic actuator.

Example

- Valve breakaway torque: 565 Nm.
- Minimum safety factor of 1.3: 734 Nm.
- Minimum air pressure: 4 Bar.

Result

-Actuator selection: RT1000DA/ 861 Nm.

Ball valve operating curve

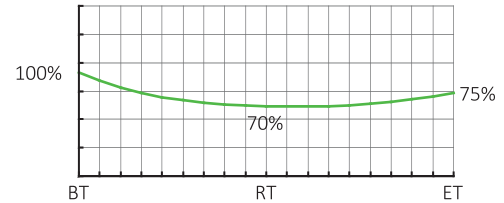

Butterfly valve operating curve

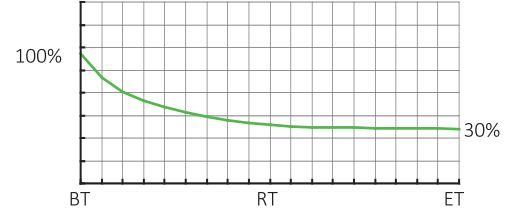

BT= Break torque RT= Run torque ET= End torque

Actuator torque versus valve torque

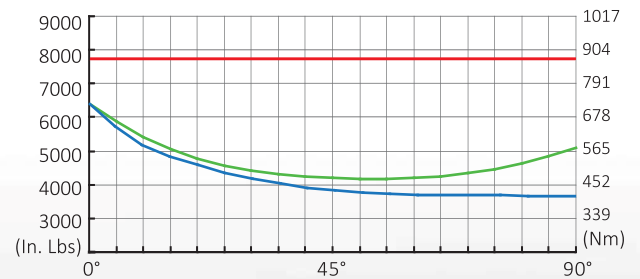

0° = Break torque

45° = Run torque

90° = End torque

Red = Actuator torque

Green = Ball valve torque

Blue = Butterfly valve torque



SIZING INFORMATION

Example for sizing a spring-return pneumatic actuator

- The important points for sizing spring return actuators are the same as the double acting actuators except for the valve closing torque.

Breakaway torque and closing torque on control valve

- Torque required to open the valve under a specific operating condition (fluid, temperature, operating pressure, etc.).

Operating conditions

- Temperature, concentration, viscosity of the fluid.
- Gas or liquid, lubricating or non-lubricating.
- Presence of solids that form deposits.
- Differential pressure across the valve.

Valve closing torque

- Most valve manufacturers do not specify the closing torque of the valve. The solution is to use the break to open torque to calculate the closing torque as this value is always higher and normally no safety factor is required.

Valve opening torque

- If no safety factor is specified for the breakaway torque, a factor of at least 1.3 (30% safety) should be included when sizing the spring-return pneumatic actuator.

Most common application: SPRING TO CLOSE

- When the valve is closing, the springs move from compression to the relax mode. The compressed springs generate enough force required for the closing torque of the valve.
- When the valve is opening, springs are compressed and under load. The opening force required under given air supply pressure must be greater than the break to open torque of the valve, differential line pressure and the force to compress the springs. This will require a larger bore (piston diameter) than a double acting actuator.

Note: The same principle applies for spring to open application.

HOW TO ORDER

Unit	1	2	3	4	5	6	Product code
Content	Series	Model	Acting Type	Spring Qty.	Travel	Custom-tailor	RT020 SR K10
Example	RT	020	Spring Acting	10 PCS	None	None	
Code	RT		SR	K10			

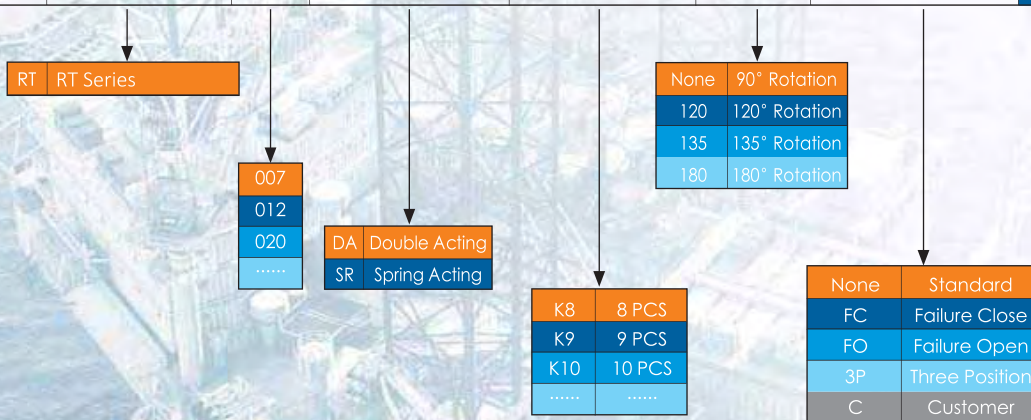

RT SERIES

PNEUMATIC RACK & PINION ACTUATOR

SIZING INFORMATION

Ball Valve Example / Spring to Close

- Valve break to open torque: 565Nm 4Bar
- Safety factor 1.3: 735Nm 4Bar
- Valve close torque (75% of Break to Open): 424Nm 4Bar
- Safety factor 1.3: 551Nm 4Bar

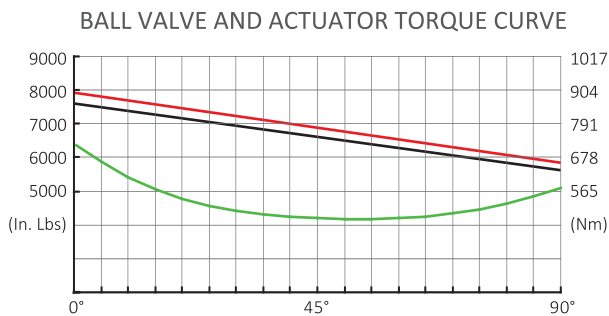

0° = Break torque
45° = Run torque
90° = End torque
Red = Spring return torque
Black = Air to spring torque
Green = Ball valve torque

Result

- Actuator selection: RT1800SR K8 FC/4Bar

Butterfly Valve Example / Spring to Close

- Valve break to open torque: 565Nm 4Bar
- Safety factor 1.3: 735Nm 4Bar
- Valve close torque (75% of Break to Open): 170Nm 4Bar
- Safety factor 1.3: 220Nm 4Bar

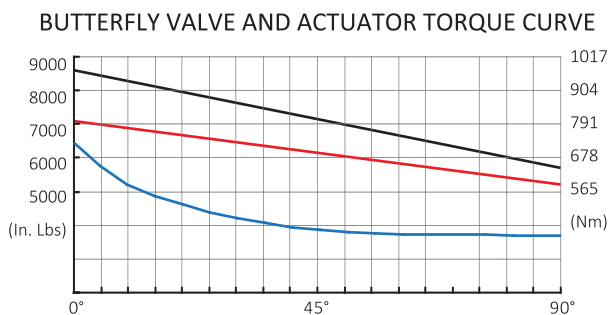

0° = Break torque
45° = Run torque
90° = End torque
Red = Spring return torque
Black = Air to spring torque
Blue = Butterfly valve torque

Result

- Actuator selection: RT1800SR K7 FC/4Bar

Notes:

Particular attention must be given to the available minimum air pressure when sizing a rack and pinion pneumatic actuator.

All spring-return actuators are normally one or two sizes larger than the double-acting pneumatic actuators for the same control valve because of the reduced available torques on the air side.

In the case of actuators that open by using spring force (rotation of the piston by 180° to reverse the direction of rotation), the spring must apply the break to open torque and the air torque must be large enough to close the valve once more.

COATING OPTION / TECHNICAL DATA

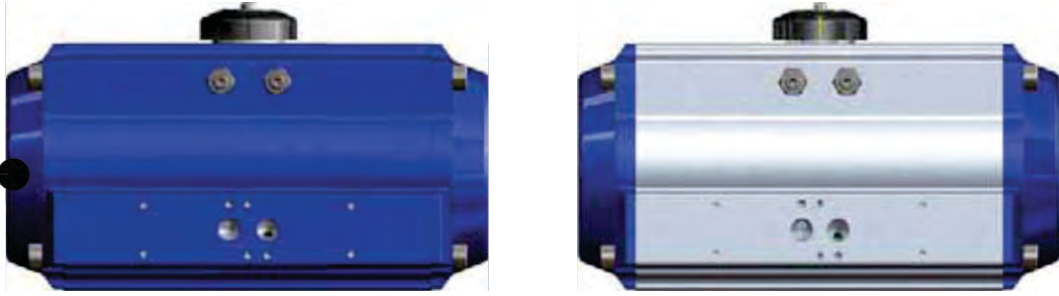

- Body**
 - Aluminum alloy anodized (STANDARD)
 - Aluminum alloy anodized plus polyester coating (OPTION)
 - Aluminum alloy anodized plus two-component polyurethane epoxy coating (OPTION)
 - Aluminum alloy anodized plus PTFE coating (OPTION)
 - Aluminum alloy anodized plus Halar Coating (OPTION)
 - Other materials available on request
- End-Caps**
 - Aluminum alloy polyester coating (STANDARD)
 - Aluminum alloy anodized plus polyester coating (OPTION)
 - Aluminum alloy anodized plus two-component polyurethane epoxy coating (OPTION)
 - Aluminum alloy anodized plus PTFE coating (OPTION)
 - Aluminum alloy anodized plus Halar Coating (OPTION)
 - Other materials available on request
- Shaft**
 - Alloy steel nickel coating (STANDARD)
 - Alloy steel Quench-Polish-Quench treatment (OPTION)
 - SS304 stainless steel (OPTION)
 - SS316 stainless steel (OPTION)
- Fastner**
 - SS304 stainless steel (STANDARD)
 - SS316 stainless steel (OPTION)
 - SS304 stainless steel plus two-component polyurethane epoxy coating (OPTION)

Technical data

Model	RT020DA		RT035DA		RT050DA		RT075DA		RT110DA		RT160DA		RT255DA		RT435DA	
	D	S	D	S	D	S	D	S	D	S	D	S	D	S	D	S
Cylinder Bore (mm)	52		63		75		83		92		105		125		140	
Cylinder Bore (inch)	2.1		2.5		3.0		3.3		3.7		4.13		4.92		5.51	
Air Volume Opening (L)	0.1		0.2		0.3		0.4		0.6		0.85		1.5		2.5	
Air Volume Opening (Cu.In.)	6.1		12.2		18.3		24.4		36.6		51.85		91.5		152.5	
Air Volume Closing (L)	0.2		0.3		0.4		0.5		0.7		1		2		3	
Air Volume Closing (Cu.In.)	9.2		15.3		24.4		30.5		42.7		61		122		183	
Approximate Weight (Kg)	1.4	1.5	2.1	2.3	2.8	3.0	3.4	3.8	4.8	5.4	6.0	6.9	9.5	11	14	16
Approximate Weight (Lbs)	3.1	3.3	4.6	5.1	6.2	6.6	7.5	8.4	10.6	11.9	13.2	15.2	21.0	24.3	30.9	35.3

Model	RT665DA		RT1000DA		RT1200DA		RT1800DA		RT2700DA		RT3800DA		RT5700DA		RT8000DA	
	D	S	D	S	D	S	D	S	D	S	D	S	D	S	D	S
Cylinder Bore (mm)	160		190		210		240		270		300		350		400	
Cylinder Bore (inch)	6.30		7.48		8.3		9.5		10.7		11.81		13.78		15.75	
Air Volume Opening (L)	3.5		5		7.5		10		16		25		40		50	
Air Volume Opening (Cu.In.)	213.5		305		457.5		610		976		1525		2440		3050	
Air Volume Closing (L)	4		5		7.5		12		20		30		50		60	
Air Volume Closing (Cu.In.)	244		305		457.5		732		1220		1830		3050		3660	
Approximate Weight (Kg)	21	24	34	40	40	48	58	68	85	103	120	140	180	220	290	330
Approximate Weight (Lbs)	46.3	53.0	75.0	88.3	88.3	106	128	150.1	187.6	227.3	264.8	309	397.2	485.5	639.9	728.2





A SUBSIDIARY OF AR CONTROLS®

PRODUCT WARRANTY

AR Controls will at its discretion repair or replace without charge or refund the purchase price for products supplied, which prove to be defective in matter or workmanship provided that, in each case the product has been properly installed and is used in the service for which it was recommended, and that the written claim, specifying the alleged defect is presented to AR Controls within 18 months from the date of shipment or within 12 months from date of installation, whichever date occurs first. AR Controls shall in no event be liable for the following cost, which includes but is not limited to costs associated with; consequential damages, labour, equipment or engineering costs related to the repair or replacement of defective equipment.

The warranty stated in this paragraph is in lieu of all other warranties, either express or implied. With respect to warranties, this paragraph states the buyer's exclusive remedy and AR Controls' exclusive liability."

14 CHROME STREET, CE6,
VANDERBIJLPARK, 1900, SOUTH AFRICA



SALES@ARCONTROLS.COM



+27 (16) 981 4551



www.arcontrols.com

Printed in South Africa

August 2022

B_03_SERRT_LS_0822_4